



Harkness Screens UK
 Tel +44 (0) 1438 725200
 Fax +44 (0) 1438 344400

E-Mail sales@harkness-screens.com
 www.harkness-screens.com

Harkness Screens USA
 Tel +1 (540) 370 1590
 Fax +1 (540) 370 1592

**WALL/CEILING SCREEN
 BEST-VIEW
 PRODUCT DATA SHEET**

Document Ref DS-058 Issue 3 Jan 2007

Best-View Wall/Ceiling screens are manually operated screens allowing a choice of mounting options. The screens feature a rigid square steel case incorporating matt white projection surfaces up to 244 x 244cm (96" x 96"). Best View's nylon bearings ensure smooth, quiet and dependable operation and the screens meet the highest standards for quality and reliability.

Application

Typical applications include:

- Educational establishments
- Training rooms
- Conference rooms
- Licensed premises / clubs

GENERAL DIMENSIONS – NOT TO SCALE

All dimensions are in mm

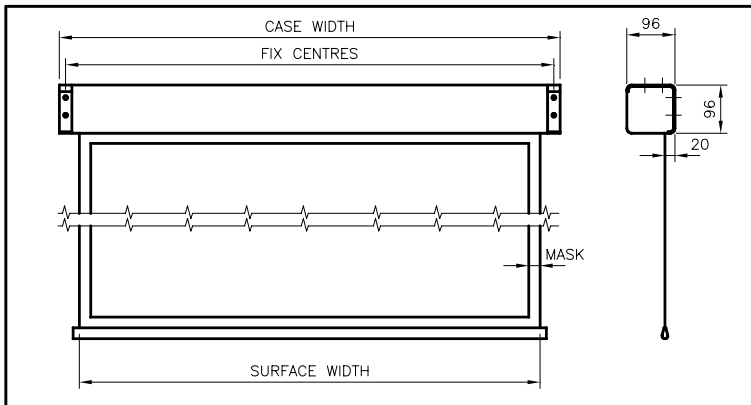

Enlarged view of end fixings

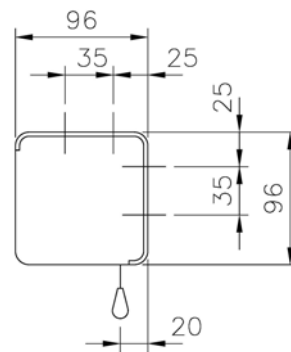

All fixing holes 2.5mm diameter

Surface Size H x W	Overall case width	Installation width
152 x 152cm – 60" x 60"	165cm – 65.0"	162.5cm – 64.0"
178 x 178cm – 70" x 70"	192cm – 75.6"	189.5cm – 74.6"
213 x 213cm – 84" x 84"	225cm – 88.6"	222.5cm – 87.6"
244 x 244cm – 96" x 96"	256cm – 100.8"	253.5cm – 99.8"
Screen Height	180cm (6.00ft)	

Bottom bar width	Shipping wt	Net wt	Black Masking Borders
152 x 152cm – 60" x 60"	8.4kg (18.5lb)	7kg (15.4lb)	152 x 152cm – 60" x 60" 30mm – 1.20"
178 x 178cm – 70" x 70"	11kg (24.2lb)	8.1kg (17.8lb)	178 x 178cm – 70" x 70" 30mm – 1.20"
213 x 213cm – 84" x 84"	14kg (30.8lb)	10.5kg (23.1lb)	213 x 213cm – 84" x 84" 40mm – 1.60"
244 x 244cm – 96" x 96"	15.8kg (34.7lb)	12kg (26.4lb)	244 x 244cm – 96" x 96" 40mm – 1.60"

General Detail

Construction	Rigid square steel case. Off-white epoxy coated finish Colour matched durable moulded plastic end caps Nylon bearings for smooth, quiet operation Ø45mm (1.77") aluminium tube screen roller
Mounting	Built-in fittings for direct wall or ceiling fixings Extension brackets for wall fixing: BV-WEB 6; BV-WEB 23
Screen Options	Matt White, gain 1 Black masking borders
Operating	Manual, pull down Locks at intervals accommodating various picture formats
NOTE:	Comprehensive installation instructions accompany screen.

In the interest of product enhancement, Harkness Screens reserves the right to introduce modifications or alterations without notice