



**Harkness Screens UK**  
 Tel +44 (0) 1438 725200  
 Fax +44 (0) 1438 344400

E-Mail [sales@harkness-screens.com](mailto:sales@harkness-screens.com)  
[www.harkness-screens.com](http://www.harkness-screens.com)

**Harkness Screens USA**  
 Tel +1 (540) 370 1590  
 Fax +1 (540) 370 1592

**TRIPOD SCREEN  
 VIEW-LITE  
 PRODUCT DATA SHEET**

**Document Ref DS-120 Issue 3 April 2009**

A ruggedly constructed tripod screen of sizes from 50" to 92" square. Carrying case included.

**Application**

Typical applications include:

- Training rooms • Classrooms • Offices • Hire stock • Home cinema

**GENERAL DIMENSIONS – NOT TO SCALE**

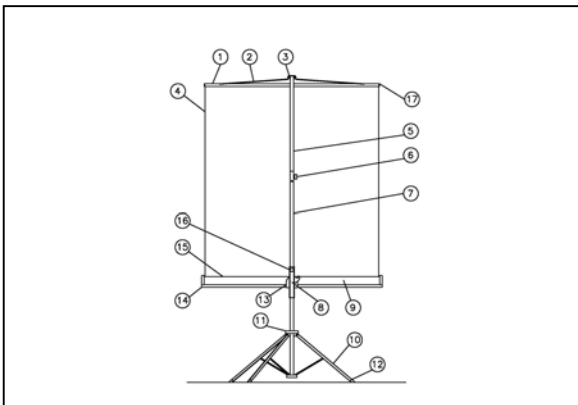

**Rear View of Screen – Key Components**

- |                       |                        |
|-----------------------|------------------------|
| 1. Top Bar            | 10. Tripod Base        |
| 2. Saddle             | 11. Leg Bracket        |
| 3. Screen Handle      | 12. Feet/Rubber Tipped |
| 4. Screen Surface     | 13. Tension Lever Lock |
| 5. Extension Tube     | 14. Barrel End Caps    |
| 6. Riser Locking Knob | 15. Screen Barrel      |
| 7. Bottom Tube        | 16. Red Locking Knob   |
| 8. Handle             | 17. End Caps           |
| 9. Spring Roller      |                        |

Surface Size H x W	Image Size H x W	Stock Code	Weight	Dimensions when closed
137 x 137cm – 54" x 54"	127 x 127cm – 50" x 50"	VL-MW50	10kg	10 x 19 x 158cm (4 x 7.5 x 62")
163 x 163cm – 64" x 64"	153 x 153cm – 60" x 60"	VL-MW60	12kg	10 x 19 x 178cm (4 x 7.5 x 70")
190 x 190cm – 75" x 75"	180 x 180cm – 70" x 70"	VL-MW70	14kg	10 x 19 x 202cm (4 x 7.5 x 80")
223 x 223cm – 88" x 88"	213 x 213cm – 84" x 84"	VL-MW84	16kg	10 x 19 x 249cm (4 x 7.5 x 98")
244 x 244cm – 96" x 96"	234 x 234cm – 92" x 92"	VL-MW96	18kg	10 x 19 x 265cm (4 x 7.5 x 104")

**General Detail**

**Construction** 70mm (2.75") diameter 20 gauge embossed steel octagonal case with flat back design.  
 RAL 9010 powder coated flat steel end caps.  
 Finished in white RAL 9010 powder coat.  
 Heavy gauge aluminium gable constructed legs with anti-scratch rubber feet.  
 Metal saddle with plated steel pull fastened to top slat.  
 1.2m upright tube and 1.0m extension tube.

**Mounting** Self-supporting floor standing. Two part system for ease of handling.

**Screen Roller** Rigid metal tube for surface rolling, mounted on integral bearings.

**Surface** Maximum size 244cm (96") x 244cm (96").  
 Top edge mounted into metal strip in tubular steel slat.

**Operating** Manual: Variable height bottom friction lock / pre-located plunger locks for extension tube.  
 Limits: Multi-format adjustable.  
 Nominal Weight: As above.

**Accessories** Screen carrying case included.

In the interest of product enhancement, Harkness Screens reserves the right to introduce modifications or alterations without notice